

EANCOM[®] 2002 S3

IFTMBC

Booking confirmation message

Edition 2016

1. Introduction.....	2
2. Message Structure Chart	4
3. Branching Diagram.....	5
4. Segments Description	7
5. Segments Layout.....	9
6. Example(s)	30

1. Introduction

Status

MESSAGE TYPE : IFTMBC
REFERENCE DIRECTORY : D.01B
EANCOM® SUBSET VERSION : 003

Definition

A message from a carrier or forwarder, to the consignor booking services, providing confirmation of a booking for a specified consignment. A confirmation may indicate that the booking of a consignment is accepted, pending, conditionally accepted or rejected.

The conditions under which requested services will take place may be given in this message.

Principles

The message is a single consignment message which can be used by all modes of transport for the forwarding and transport of goods from any origin to any destination, regardless of route or prevailing commercial practice.

The message can be used whenever a confirmation of the booking of a consignment is deemed necessary as an answer to a firm booking message for a specific consignment.

When the message is used to confirm that the complete booking is accepted or pending then only the header information should be sent.

Only when a booking is not accepted the detail section of the message may be resent to indicate the cause for non-acceptance of the goods items detailed.

In addition to the main principles detailed above, a number of general principles also apply;

- A consignment may contain several goods items.
- A consignment is identified by a consignors reference number (code CU) qualified in the RFF segment.
- Goods items may or may not be containerised.
- Goods items may be transported in one or more containers, and a single container may contain one or more goods items.
- One goods item may be related to one or more customs tariff codes.
- Goods items related to one customs tariff code may be carried in one or more containers.
- Pre-carriage (advanced haulage) and/or on-carriage (destination haulage) of the consignment may take place in different steps, each step specified with its own transport details group.
- Transport devices, which have the ability of powered movement on their own, are specified in the transport details group. Other load or transport devices are specified as equipment.
- Packaging for goods items can be expressed at up to three levels.
- A goods item consists of one or more despatch units that adhere to the same package type and goods description.
- A despatch unit is the unit of cargo that will be handled and to which an SSCC can be affixed.

A number of generic transport terms are used in this specification, to be described as:

CONSIGNEE

the organisation (party) which has the intention to receive the goods.

1. Introduction

CONSIGNOR

the party ordering transport, orders a carrier to collect goods for transportation.

CONSIGNMENT

a collection of goods items to be transported from one or many despatch locations to one or many delivery locations. (synonym: shipment).

CARRIER

the party contracted by the consignor or forwarder to transport goods.

DESPATCH LOCATION

the physical location from which goods for transport are shipped.

DELIVERY LOCATION

the physical location to which goods for transport are finally delivered.

EQUIPMENT

material resources necessary to facilitate the transport and handling of cargo. Transport equipment does under the given circumstances not have the ability to move by its own propulsion (e.g. sea container, trailer, unit load device, pallet).

FORWARDER

the party contracted by the consignor to arrange to have the goods transported.

GOODS ITEM

a collection of products normally grouped together for transport purposes, e.g. 12 pallets of foodstuffs.

LINE ITEM

a specific product identified and defined for trade purposes, e.g. a case of flour containing 24 packets of 250 grams.

MODE OF TRANSPORT

the method of transport used for the conveyance of goods or persons, e.g. by rail, by road, by sea.

MEANS OF TRANSPORT

the vehicle used for the transport of goods or persons, e.g. aircraft, truck, vessel.

PLACE OF ACCEPTANCE

the place at which the **responsibility** of the carrier starts.

PLACE OF DELIVERY

the place at which the responsibility of the carrier ends.

TYPE OF MEANS OF TRANSPORT

the type of vehicle used in the transport process, e.g. wide body, tank truck, passenger vessel.

TYPE OF EQUIPMENT

the type of material used, e.g. 40 feet container, four way pallet, mafi trailer.

2. Message Structure Chart

Booking Confirmation Heading Section

UNH	1	M	1	- Message header
BGM	2	M	1	- Beginning of message
DTM	3	C	9	- Date/time/period
FTX	4	C	99	- Free text
SG2		C	99	- RFF-DTM
RFF	5	M	1	- Reference
DTM	6	C	9	- Date/time/period
SG3		C	99	- TDT-DTM-SG4
TDT	7	M	1	- Details of transport
DTM	8	C	9	- Date/time/period
SG4		C	99	- LOC
LOC	9	M	1	- Place/location identification
SG6		C	99	- NAD
NAD	10	M	1	- Name and address

Booking Confirmation Detail Section

SG9		C	999	- GID-FTX-SG13
GID	11	M	1	- Goods item details
FTX	12	C	9	- Free text
SG13		C	9	- RFF
RFF	13	M	1	- Reference

Booking Confirmation Summary Section

UNT	14	M	1	- Message trailer
-----	----	---	---	-------------------

3. Branching Diagram

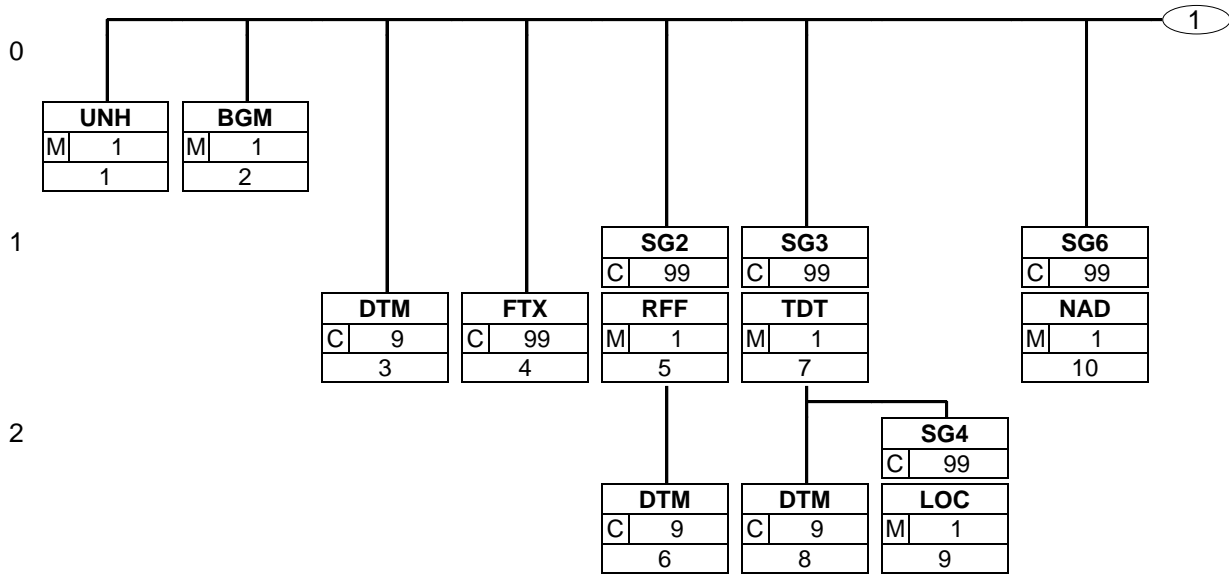

3. Branching Diagram

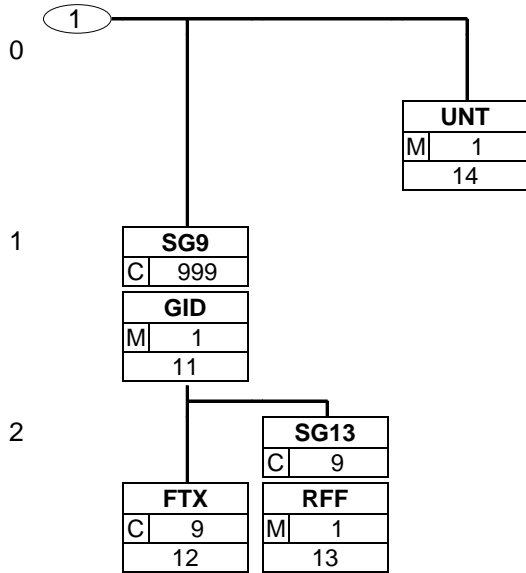

4. Segments Description

Booking Confirmation Heading Section

- UNH - M 1 - Message header
This segment is used to head, identify and specify a message.
- BGM - M 1 - Beginning of message
This segment is used to indicate the type and function of a message and to transmit the identifying number.
- DTM - C 9 - Date/time/period
This segment is used to specify any dates applicable to the complete booking confirmation message.
- FTX - C 99 - Free text
This segment is used to provide free form or coded text information related to the entire message.
- SG2** - C 99 - **RFF-DTM**
A group of segments containing a reference and constants which apply to the entire message.
- RFF - M 1 - Reference
This segment is used to specify references relating to the booking confirmation.
- DTM - C 9 - Date/time/period
This segment is used to specify any dates related to the previous RFF segment.
- SG3** - C 99 - **TDT-DTM-SG4**
A group of segments to indicate details of the movement of goods such as mode and means of transport, locations, departure, and arrival date(s) and time(s).
- TDT - M 1 - Details of transport
This segment is used to propose amendments to the transport details previously specified in the booking message. The identification of the main carriage transport is mandatory when this segment is included in the message.
- DTM - C 9 - Date/time/period
This segment is used to specify any dates relating to the transport specified in the previous TDT segment.
- SG4** - C 99 - **LOC**
A group of segments to specify a location related to this leg of transport.
- LOC - M 1 - Place/location identification
This segment is used to identify any locations related to the transport details previously specified.
- SG6** - C 99 - **NAD**
A group of segments to identify the trading partners involved in the booking confirmation.
- NAD - M 1 - Name and address
This segment is used to identify the trading partners involved in the booking confirmation. Identification of the party arranging carriage of the goods and the consignor is mandatory in the booking confirmation message.

Booking Confirmation Detail Section

- SG9** - C 999 - **GID-FTX-SG13**
A group of segments to describe the goods items for which transport is undertaken.

4. Segments Description

- GID - M 1 - Goods item details
This segment is used to provide details on the goods item for which space was previously booked. This segment is the trigger segment for the detail section of the message. The detail section of the message may only be used when the booking is not accepted and is used to indicate the reason for non-acceptance of the goods item.
- FTX - C 9 - Free text
This segment is used to provide free form or coded text information related to the goods item.
- SG13 - C 9 - RFF**
A group of segments to identify references to a goods item.
- RFF - M 1 - Reference
This segment is used to specify references relating to the current goods item only.

Booking Confirmation Summary Section

- UNT - M 1 - Message trailer
The UNT segment is a mandatory UN/EDIFACT segment. It must always be the last segment in the message.

5. Segments Layout

This section describes each segment used in the EANCOM® Booking confirmation message. The original EDIFACT segment layout is listed. The appropriate comments relevant to the EANCOM® subset are indicated.

Notes:

1. The segments are presented in the sequence in which they appear in the message. The segment or segment group tag is followed by the (M)andatory / (C)onditional indicator, the maximum number of occurrences and the segment description.
2. Reading from left to right, in column one, the data element tags and descriptions are shown, followed by in the second column the EDIFACT status (M or C), the field format, and the picture of the data elements. These first pieces of information constitute the original EDIFACT segment layout.

Following the EDIFACT information, EANCOM® specific information is provided in the third, fourth, and fifth columns. In the third column a status indicator for the use of (C)onditional EDIFACT data elements (see 2.1 through 2.3 below), in the fourth column the restricted indicator (see point 3 on the following page), and in the fifth column notes and code values used for specific data elements in the message.

- 2.1 (M)andatory data elements in EDIFACT segments retain their status in EANCOM®.
- 2.2 Additionally, there are five types of status for data elements with a (C)onditional EDIFACT status, whether for simple, component or composite data elements. These are listed below and can be identified when relevant by the following abbreviations:

- REQUIRED	R	Indicates that the entity is required and must be sent.
- ADVISED	A	Indicates that the entity is advised or recommended.
- DEPENDENT	D	Indicates that the entity must be sent in certain conditions, as defined by the relevant explanatory note.
- OPTIONAL	O	Indicates that the entity is optional and may be sent at the discretion of the user.
- NOT USED	N	Indicates that the entity is not used and should be omitted.

- 2.3 If a composite is flagged as **N, NOT USED**, all data elements within that composite will have blank status indicators assigned to them.
3. Status indicators detailed in the fourth column which directly relate to the code values detailed in the fifth **column** may have two values:

- RESTRICTED	*	A data element marked with an asterisk (*) in the fourth column indicates that the listed codes in column five are the only codes available for use with this data element, in this segment, in this message.
- OPEN		All data elements where coded representation of data is possible and a restricted set of code values is not indicated are open (no asterisk in fourth column). The available codes are listed in the EANCOM® Data Elements and Code Sets Directory. Code values may be given as examples or there may be a note on the format or type of code to be used.

4. Different colours are used for the code values in the segment details: restricted codes are in red and open codes in blue.

5. Segments Layout

Segment number: 1

UNH - M 1 - Message header					
Function: To head, identify and specify a message.					
		EDIFACT	GS1	*	Description
0062	Message reference number	M an..14	M		Senders unique message reference. Sequence number of the messages in the interchange. DE 0062 in the UNT will be identical. Sender generated.
S009	MESSAGE IDENTIFIER	M	M		
0065	Message type	M an..6	M	*	IFTMBC = Booking confirmation message
0052	Message version number	M an..3	M	*	D = Draft version/UN/EDIFACT Directory
0054	Message release number	M an..3	M	*	01B = Release 2001 - B
0051	Controlling agency	M an..2	M	*	UN = UN/CEFACT
0057	Association assigned code	C an..6	R	*	EAN003 = GS1 version control number (GS1 Permanent Code) Indicates that the message is the EANCOM version 003 of the UNSM Booking Confirmation message.
0068	Common access reference	C an..35	N		
S010	STATUS OF THE TRANSFER	C	N		
0070	Sequence of transfers	M n..2			
0073	First and last transfer	C a1			
<p>Segment Notes:</p> <p>This segment is used to head, identify and specify a message. DE's 0065, 0052, 0054, and 0051: Indicate that the message is a UNSM Booking Confirmation message based on the D.01B directory under the control of the United Nations.</p> <p>Example: UNH+ME000001+IFTMBC:D:01B:UN:EAN003'</p>					

5. Segments Layout

Segment number: 2

BGM - M 1 - Beginning of message				
Function: To indicate the type and function of a message and to transmit the identifying number.				
		EDIFACT	GS1	* Description
C002	DOCUMENT/MESSAGE NAME	C	R	
1001	Document name code	C an..3	R	* 770 = Booking confirmation
1131	Code list identification code	C an..17	N	
3055	Code list responsible agency code	C an..3	N	
1000	Document name	C an..35	O	
C106	DOCUMENT/MESSAGE IDENTIFICATION	C	R	
1004	Document identifier	C an..35	R	Confirmation number assigned by the document sender. For global unique identification of documents Global Document Type Identifier (GDTI) is available.
1056	Version identifier	C an..9	N	
1060	Revision identifier	C an..6	N	
1225	Message function code	C an..3	R	* 9 = Original 31 = Copy The message function, coded is a critical data element in this segment. It applies to all data indicated in the message. The following definitions apply for the restricted codes: 9 = Original - An original transmission of a Booking Confirmation. 31 = Copy - Copy of the booking confirmation for a third party for information purposes.
4343	Response type code	C an..3	R	* AJ = Pending AP = Accepted CA = Conditionally accepted RE = Rejected AP - Accepted - The previously sent firm booking has been fully accepted. CA - Conditionally accepted - The previously sent firm booking has been conditionally accepted subject to some minor amendments, e.g. no room on the requested sailing. Details of the amendments only may be specified at the header level of the message. PE - Pending - The previously sent firm booking message has been received but has not yet been processed and is pending final confirmation. RE - Rejected - The previously sent firm booking has not been accepted by the forwarder or carrier. Only those goods items responsible for non-acceptance of the booking may be detailed in group 9.

5. Segments Layout

Segment Notes:

This segment is used to indicate the type and function of a message and to transmit the identifying number.
All references other than the document number DE 1004 are to be put in the RFF segment.

Example:

5. Segments Layout

Segment number: 2

BGM+770+31041+9+AP'

5. Segments Layout

Segment number: 3

DTM - C 9 - Date/time/period					
Function: To specify date, and/or time, or period.					
		EDIFACT	GS1	* Description	
C507	DATE/TIME/PERIOD	M	M		
2005	Date or time or period function code qualifier	Man..3	M	*	10 = Shipment date/time, requested 17 = Delivery date/time, estimated 137 = Document/message date/time 143 = Acceptance date/time of goods 179 = Booking date/time 199 = Positioning date/time of goods 200 = Pick-up/collection date/time of cargo 234 = Collection date/time, earliest 235 = Collection date/time, latest
2380	Date or time or period value	C an..35	R		
2379	Date or time or period format code	C an..3	R		102 = CCYYMMDD 203 = CCYYMMDDHHMM 718 = CCYYMMDD-CCYYMMDD 719 = CCYYMMDDHHMM- CCYYMMDDHHMM
Segment Notes: This segment is used to specify any dates applicable to the complete booking confirmation message. DE 2005: Identification of the 'Document/message date/time' (code value 137) is mandatory in an EANCOM message. Example: DTM+137:20021201:102'					

5. Segments Layout

Segment number: 4

FTX - C 99 - Free text					
Function: To provide free form or coded text information.					
		EDIFACT	GS1	*	Description
4451	Text subject code qualifier	M an..3	M	*	CHG = Change information NAI = Non-acceptance information (GS1 Temporary Code)
4453	Free text function code	C an..3	O		1 = Text for subsequent use
C107	TEXT REFERENCE	C	D		This composite is only used when trading partners have agreed to use mutually defined code values.
4441	Free text value code	Man..17	M		
1131	Code list identification code	C an..17	O		
3055	Code list responsible agency code	C an..3	D		9 = GS1 91 = Assigned by supplier or supplier's agent
C108	TEXT LITERAL	C	D		This composite is only used if coded text can not be used.
4440	Free text value	Man..512	M		
4440	Free text value	C an..512	O		
4440	Free text value	C an..512	O		
4440	Free text value	C an..512	O		
4440	Free text value	C an..512	O		
3453	Language name code	C an..3	D		ISO 639 two alpha code This data element is only used when non coded free text has been provided in data element C108.
4447	Free text format code	C an..3	N		
Segment Notes:					
<p>This segment is used to provide free form or coded text information related to the entire message. Use of this segment in free form is not recommended since it may inhibit automatic processing of the booking confirmation message. Coded references to standard texts is an available functionality which enables automatic processing and reduces transmission overheads. Standard texts should be mutually defined between trading partners and can be used to cover legal or other requirements. This segment can be used to indicate the reason for the non-acceptance of a previous complete booking or amendments at the message level.</p>					
<p>Example: FTX+NAI+1+001::91' Standard text 001 = 'Booking not accepted until outstanding accounts settled'.</p>					

5. Segments Layout

Segment number: 5

SG2	- C	99 - RFF-DTM			
RFF	- M	1 - Reference			
Function: To specify a reference.					
		EDIFACT	GS1	*	Description
C506	REFERENCE	M	M		
1153	Reference code qualifier	Man..3	M		BN = Booking reference number CT = Contract number CU = Consignor's reference number It is mandatory to specify the code value 'CU' in this segment in order to establish the link between the booking confirmation message and the firm booking being responded to. The code 'BN' is only used to identify a booking which was left as pending in a previously sent booking confirmation.
1154	Reference identifier	C an..70	R		
1156	Document line identifier	C an..6	N		
4000	Reference version identifier	C an..35	N		
1060	Revision identifier	C an..6	N		
Segment Notes: This segment is used to specify references relating to the booking confirmation.					
Example: RFF+CU:52114'					

5. Segments Layout

Segment number: 6

SG2	- C	99 - RFF-DTM			
DTM	- C	9 - Date/time/period			
Function:					
To specify date, and/or time, or period.					
		EDIFACT	GS1	*	Description
C507	DATE/TIME/PERIOD	M	M		
2005	Date or time or period function code qualifier	Man..3	M	*	171 = Reference date/time
2380	Date or time or period value	C an..35	R		
2379	Date or time or period format code	C an..3	R		102 = CCYYMMDD 203 = CCYYMMDDHHMM
Segment Notes:					
This segment is used to specify any dates related to the previous RFF segment.					
Example:					
DTM+171:20021125:102'					

5. Segments Layout

Segment number: 7

SG3	- C	99 - TDT-DTM-SG4			
TDT	- M	1 - Details of transport			
Function:					
To specify the transport details such as mode of transport, means of transport, its conveyance reference number and the identification of the means of transport.					
		EDIFACT	GS1	*	Description
8051	Transport stage code qualifier	M an..3	M		10 = Pre-carriage transport 20 = Main-carriage transport 30 = On-carriage transport
8028	Means of transport journey identifier	C an..17	O		Reference number covering the transport.
C220	MODE OF TRANSPORT	C	A		
8067	Transport mode name code	C an..3	R		10 = 20 = 30 = 40 = 60 =
8066	Transport mode name	C an..17	N		
C228	TRANSPORT MEANS	C	O		Die Datenelemente 8179 und 8178 werden nur dann benutzt, wenn die Transportart explizit identifiziert werden muss, d. h. wenn eine allgemeine Beschreibung, wie Straßentransport, nicht ausreicht.
8179	Transport means description code	C an..8	D		23 = Rail bulk car 31 = Truck
8178	Transport means description	C an..17	D		
C040	CARRIER	C	O		
3127	Carrier identifier	C an..17	A		Global Location Number GLN - Format n13
1131	Code list identification code	C an..17	O		
3055	Code list responsible agency code	C an..3	D		9 = GS1
3128	Carrier name	C an..35	O		
8101	Transit direction indicator code	C an..3	N		
C401	EXCESS TRANSPORTATION INFORMATION	C	N		
8457	Excess transportation reason code	Man..3			
8459	Excess transportation responsibility code	Man..3			
7130	Customer shipment authorisation identifier	C an..17			
C222	TRANSPORT IDENTIFICATION	C	O		
8213	Transport means identification name identifier	C an..9	O		
1131	Code list identification code	C an..17	O		
3055	Code list responsible agency code	C an..3	D		DE 3055 must be used if DE 8213 is used.

5. Segments Layout

8212	Transport means identification	C an..35	R	Vehicle license plate/Aircraft number.
------	--------------------------------	----------	----------	--

5. Segments Layout

Segment number: 7

	EDIFACT	GS1	*	Description
name				
8453 Transport means nationality code	C an..3	O		ISO 3166 two alpha code
8281 Transport means ownership indicator code	C an..3	N		

Segment Notes:

This segment is used to propose amendments to the transport details previously specified in the booking message. The identification of the main carriage transport is mandatory when this segment is included in the message.

Example:

TDT+20++30+31'

Dependency Notes:

Data Elements 8179 and 8178 are only used when the type of transport must be specifically identified, that is, a generic description such as road transport is unsuitable.

5. Segments Layout

Segment number: 8

SG3	- C	99 - TDT-DTM-SG4			
DTM	- C	9 - Date/time/period			
Function:					
To specify date, and/or time, or period.					
	EDIFACT	GS1	*	Description	
C507	DATE/TIME/PERIOD	M	M		
2005	Date or time or period function code qualifier	Man..3	M	*	132 = Arrival date/time, estimated 133 = Departure date/time, estimated 190 = Transhipment date/time
2380	Date or time or period value	C an..35	R		
2379	Date or time or period format code	C an..3	R		102 = CCYYMMDD 203 = CCYYMMDDHHMM
Segment Notes:					
This segment is used to specify any dates relating to the transport specified in the previous TDT segment.					
Example:					
DTM+133:200212151000:203'					

5. Segments Layout

Segment number: 9

SG3	- C	99 - TDT-DTM-SG4			
SG4	- C	99 - LOC			
LOC	- M	1 - Place/location identification			
Function:					
To identify a place or a location and/or related locations.					
	EDIFACT	GS1	*	Description	
3227	Location function code qualifier	M an..3	M	*	9 = Place/port of loading 11 = Place/port of discharge
C517	LOCATION IDENTIFICATION	C	A		
3225	Location name code	C an..25	A		GLN - Format n13
1131	Code list identification code	C an..17	O		
3055	Code list responsible agency code	C an..3	D		9 = GS1 DE 3055 must be used if DE 3225 is used and does not contain an UN/LOCODE.
3224	Location name	C an..256	O		
C519	RELATED LOCATION ONE IDENTIFICATION	C	N		
3223	First related location name code	C an..25			
1131	Code list identification code	C an..17			
3055	Code list responsible agency code	C an..3			
3222	First related location name	C an..70			
C553	RELATED LOCATION TWO IDENTIFICATION	C	N		
3233	Second related location name code	C an..25			
1131	Code list identification code	C an..17			
3055	Code list responsible agency code	C an..3			
3232	Second related location name	C an..70			
5479	Relation code	C an..3	N		
Segment Notes:					
This segment is used to identify any locations related to the transport details previously specified.					
Example: LOC+9+5412345678908::9'					

5. Segments Layout

Segment number: 10

SG6	- C	99 - NAD			
NAD	- M	1 - Name and address			
Function:					
To specify the name/address and their related function, either by C082 only and/or unstructured by C058 or structured by C080 thru 3207.					
		EDIFACT	GS1	*	Description
3035	Party function code qualifier	M an..3	M		CA = Carrier CG = Carrier's agent CN = Consignee CZ = Consignor FW = Freight forwarder
C082	PARTY IDENTIFICATION DETAILS	C	A		
3039	Party identifier	M an..35	M		For identification of parties it is recommended to use GLN - Format n13.
1131	Code list identification code	C an..17	N		
3055	Code list responsible agency code	C an..3	R	*	9 = GS1
C058	NAME AND ADDRESS	C	O		This composite may only be used to fulfill the requirements of directive 2003/58/EC, article 4.
3124	Name and address description	M an..35	M		
3124	Name and address description	C an..35	O		
3124	Name and address description	C an..35	O		
3124	Name and address description	C an..35	O		
3124	Name and address description	C an..35	O		
C080	PARTY NAME	C	D		
3036	Party name	M an..35	M		Party Name in clear text.
3036	Party name	C an..35	O		
3036	Party name	C an..35	O		
3036	Party name	C an..35	O		
3036	Party name	C an..35	O		
3045	Party name format code	C an..3	O		
C059	STREET	C	D		
3042	Street and number or post office box identifier	M an..35	M		Building Name/Number and Street
3042	Street and number or post office box identifier	C an..35	O		Name and/or P.O. Box
3042	Street and number or post office box identifier	C an..35	O		
3042	Street and number or post office box identifier	C an..35	O		
3164	City name	C an..35	D		City/Town, clear text.
C819	COUNTRY SUB-ENTITY DETAILS	C	D		
3229	Country sub-entity name code	C an..9	O		

5. Segments Layout

Segment number: 10

	EDIFACT	GS1	*	Description
1131 Code list identification code	C an..17	O		
3055 Code list responsible agency code	C an..3	O		
3228 Country sub-entity name	C an..70	O		County/State, clear text.
3251 Postal identification code	C an..17	D		Postal Code
3207 Country name code	C an..3	D		ISO 3166 two alpha code

Segment Notes:

This segment is used to identify the trading partners involved in the booking confirmation. Identification of the party arranging carriage of the goods and the consignor is mandatory in the booking confirmation message. The only parties which may be amended in a booking confirmation message are the carrier or carrier's agent when a consignor uses the services of a freight forwarder.

Example:

NAD+CZ+5411234512309::9'
 NAD+FW+5412345123453::9'

Dependency Notes:

The following composites and data elements are only used when a coded name and address can not be used. The affected composites and data elements are as follows:
 C080 - C059 - 3164 - C819 - 3251 - 3207

5. Segments Layout

Segment number: 11

SG9	- C	999 - GID-FTX-SG13			
GID	- M	1 - Goods item details			
Function:					
To indicate totals of a goods item.					
		EDIFACT	GS1	*	Description
1496	Goods item number	C n..5	R		Application number identifying items within the current consignment.
C213	NUMBER AND TYPE OF PACKAGES	C	N		
7224	Package quantity	C n..8			
7065	Package type description code	C an..17			
1131	Code list identification code	C an..17			
3055	Code list responsible agency code	C an..3			
7064	Type of packages	C an..35			
7233	Packaging related description code	C an..3			
C213	NUMBER AND TYPE OF PACKAGES	C	N		
7224	Package quantity	C n..8			
7065	Package type description code	C an..17			
1131	Code list identification code	C an..17			
3055	Code list responsible agency code	C an..3			
7064	Type of packages	C an..35			
7233	Packaging related description code	C an..3			
C213	NUMBER AND TYPE OF PACKAGES	C	N		
7224	Package quantity	C n..8			
7065	Package type description code	C an..17			
1131	Code list identification code	C an..17			
3055	Code list responsible agency code	C an..3			
7064	Type of packages	C an..35			
7233	Packaging related description code	C an..3			
C213	NUMBER AND TYPE OF PACKAGES	C	N		
7224	Package quantity	C n..8			
7065	Package type description code	C an..17			
1131	Code list identification code	C an..17			
3055	Code list responsible agency code	C an..3			
7064	Type of packages	C an..35			

5. Segments Layout

Segment number: 11

	EDIFACT	GS1	*	Description
7233 Packaging related description code	C an..3			
C213 NUMBER AND TYPE OF PACKAGES	C	N		
7224 Package quantity	C n..8			
7065 Package type description code	C an..17			
1131 Code list identification code	C an..17			
3055 Code list responsible agency code	C an..3			
7064 Type of packages	C an..35			
7233 Packaging related description code	C an..3			

Segment Notes:

This segment is used to provide details on the goods item for which space was previously booked. This segment is the trigger segment for the detail section of the message. The detail section of the message may only be used when the booking is not accepted and is used to indicate the reason for non-acceptance of the goods item.

Example:
 GID+1'

5. Segments Layout

Segment number: 12

SG9	- C	999 - GID-FTX-SG13			
FTX	- C	9 - Free text			
Function:					
To provide free form or coded text information.					
		EDIFACT	GS1	*	Description
4451	Text subject code qualifier	M an..3	M	*	NAI = Non-acceptance information (GS1 Temporary Code)
4453	Free text function code	C an..3	O		1 = Text for subsequent use
C107	TEXT REFERENCE	C	D		This composite is only used when trading partners have agreed to use mutually defined code values.
4441	Free text value code	M an..17	M		
1131	Code list identification code	C an..17	O		
3055	Code list responsible agency code	C an..3	D		9 = GS1 91 = Assigned by supplier or supplier's agent 92 = Assigned by buyer or buyer's agent
C108	TEXT LITERAL	C	D		This composite is only used if coded text can not be used.
4440	Free text value	M an..512	M		
4440	Free text value	C an..512	O		
4440	Free text value	C an..512	O		
4440	Free text value	C an..512	O		
4440	Free text value	C an..512	O		
3453	Language name code	C an..3	D		ISO 639 two alpha code This data element is only used when non coded free text has been provided in data element C108.
4447	Free text format code	C an..3	N		
Segment Notes:					
<p>This segment is used to provide free form or coded text information related to the goods item.</p> <p>Use of this segment in free form is not recommended since it may inhibit automatic processing of the booking confirmation message. Coded references to standard texts is an available functionality which enables automatic processing and reduces transmission overheads. Standard texts should be mutually defined between trading partners and can be used to cover legal or other requirements.</p> <p>This segment can be used to indicate the reason for the non-acceptance of the goods item.</p>					
Example:					
FTX+NAI+++NOT LICENCED TO CARRY EXPLOSIVE SUBSTANCES'					

5. Segments Layout

Segment number: 13

SG9	- C	999 - GID-FTX-SG13		
SG13	- C	9 - RFF		
RFF	- M	1 - Reference		
Function:				
To specify a reference.				
	EDIFACT	GS1	*	Description
C506	REFERENCE	M	M	
1153	Reference code qualifier	Man..3	M	BN = Booking reference number CT = Contract number CU = Consignor's reference number
1154	Reference identifier	C an..70	R	
1156	Document line identifier	C an..6	O	
4000	Reference version identifier	C an..35	N	
1060	Revision identifier	C an..6	N	
Segment Notes:				
This segment is used to specify references relating to the current goods item only.				
Example:				
RFF+CT:52114:15'				

5. Segments Layout

Segment number: 14

UNT - M 1 - Message trailer					
Function: To end and check the completeness of a message.					
		EDIFACT	GS1	*	Description
0074	Number of segments in the message	M n..6	M		The total number of segments in the message is detailed here.
0062	Message reference number	M an..14	M		The message reference numbered detailed here should equal the one specified in the UNH segment.
Segment Notes: The UNT segment is a mandatory UN/EDIFACT segment. It must always be the last segment in the message. Example: UNT+14+ME000001'					

6. Examples

Example 1 - Accepted without amendment

The following is an example of a booking confirmation where total acceptance of a previous booking for a consignment, identified by the carrier or agent using the booking reference 431-AA and the consignors reference 122, is provided.

The message, identified by the number 31041, is sent by a freight forwarder identified by GLN 5412345123450 to the consignor identified by GLN 5411234512300 on the 4th of November 2002.

The message confirms that a reservation has been made on the Sealink sailing from Calais to Dover, with the conveyance reference number 951106046, which is due to depart at 10am on the 6th of November 2002 and arrive at 6:30pm on the same day.

UNH+ME000001+IFTMBC:D:01B:UN:EAN003'	Message header
BGM+770+31041+9+AP'	Booking confirmation number 31041 (accepted)
DTM+137:20021104:102'	Message date 11th November 2002
RFF+BN:431-AA'	Booking reference number accepted: 431-AA
RFF+CU:122'	Consignor's reference number: 122
TDT+20+951106046+10++::SEALINK'	Transport by Sealink
DTM+133:200211061000:203'	Estimated departure date/time: 11th June 2002 at 10:00
DTM+132:200211061830:203'	Estimated arrival date/time: 11th June 2002 at 18:30
LOC+9+:::CALAIS'	Place of loading is Calais
LOC+11+:::DOVER'	Place of discharge is Dover
NAD+CZ+5411234512300::9'	The consignor identified with GLN 5411234512300
NAD+FW+5412345123450::9'	The freight forwarder identified with GLN 5412345123450
UNT+13+ME000001'	Total number of segments in the message equals 13

Example 2 - Rejected

The following is an example of a booking confirmation where a complete booking is rejected. The booking confirmation message is identified by the number 32155.

The message, transmitted on the 15th of July 2002, was sent by a carrier identified by GLN 5499999123459 to the consignor identified by GLN 5412345999997 and refers to the consignors reference 86/A.

The reason for non-acceptance is specified as being that the carrier does not have the necessary license to transport the goods items (chemicals) detailed in the booking message.

UNH+ME000001+IFTMBC:D:93A:UN:EAN003'	Message header
BGM+770+32155+9+RE'	Booking confirmation number 32155 (rejected)
DTM+137:20020715:102'	Message date 15th July 2002
FTX+NAI+++NOT LICENSED TO CARRY CHEMICALS'	Not acceptance reason

6. Examples

RFF+CU:86/A'	Consignor' reference number: 86/A
TDT+20++10'	Transport originally requested
NAD+CZ+5412345999997::9'	The consignor identified with GLN 5412345999997
NAD+CA+5499999123459::9'	The carrier identified with GLN 5499999123459
UNT+9+ME000001'	Total number of segments in the message equals 9

Example 3 - Conditionally accepted with amendment in heading

The following is an example of a booking confirmation where the booking is conditionally accepted subject to acceptance by the consignor of an amendment to the heading details of the message. The booking confirmation message is identified by the number 418.

The message, transmitted on the 15th of June 2002, was sent by a freight forwarder identified by GLN 5499999123459 to the consignor identified by GLN 5412345999997 and refers to the consignors reference 86/A.

All of the goods items in the consignment are accepted but the message details that space is not available on the requested sailing of the ship, SL-1423 at 10am on the 23rd of July 2002. A proposal to ship the goods on the 5pm sailing of the same ship is made and the consignor must confirm with the freight forwarder that this is acceptable.

UNH+ME000001+IFTMBC:D:01B:UN:EAN003'	Message header
BGM+770+418+9+CA'	Booking confirmation number 418 (conditionally accepted)
DTM+137:20020615:102'	Message date/time 15th June 2002
FTX+NAI+++NO SPACE AVAILABLE ON REQUESTED SAILING'	Non-acceptance information
FTX+CHG+++SAILING TIME FOR REQUESTED VOYAGE CHANGED'	Change of information in free form
RFF+CU:86/A'	Booking reference number conditionally accepted: 86/A
TDT+20++10+:::SEA CARRIERS CO LTD+++::MS SEALION'	Details of the transport
DTM+133:200207231700:203'	Departure date/time 23rd July 2002 at 17:00
NAD+CZ+5412345999997::9'	The consignor identified with GLN 5412345999997
NAD+CA+5499999123459::9'	The carrier identified with GLN 5499999123459
UNT+11+ME000001'	Total number of segments in the message equals 11

Example 4 - Rejected, reasons in detail

The following is an example of a booking confirmation where the booking is rejected with the details for rejection provided in the details section of the message. The booking confirmation message is identified by the number 6255.

6. Examples

The message, transmitted on the 20th of August 2002, was sent by a freight forwarder identified by GLN 5499999123459 to the consignor identified by GLN 5412345999997 and refers to the consignors reference 14556-2.

The message details three goods items, 15, 21, and 22 from the original consignors reference which are not accepted. The reason for non-acceptance is identified using the suppliers (of the transport services) allocated codes 025 (Export license required) and 026 (Packaging not suitable for goods item).

UNH+ME000001+IFTMBC:D:01B:UN:EAN003'	Message header
BGM+770+6255+9+RE'	Booking confirmation number 6255 (rejected)
DTM+137:20020820:102'	Message date/time 20th August 2002
RFF+CU:14556-2'	Consignor's reference number 14556-2
TDT+20++20+:::P&O FERRIES'	Details of the transport originally solicited
NAD+CZ+5412345999997::9'	The consignor identified with GLN 5412345999997
NAD+CA+54999999123459::9'	The carrier identified with GLN 54999999123459
GID+1'	First occurrence, trigger of the detail section
FTX+NAI+1+025::91'	Reason for the non-acceptance of
RFF+CU:14556-2:15'	Consignor's reference number14556-2, goods item # 15
GID+2'	Second occurrence, trigger of the detail section
FTX+NAI+1+025::91'	Reason for the non-acceptance of
RFF+CU:14556-2:21'	Consignor's reference number14556-2, goods item # 21
GID+3'	Third occurrence, trigger of the detail section
FTX+NAI+1+026::91'	Reason for the non-acceptance of
RFF+CU:14556-2:22'	Consignor's reference number14556-2, goods item # 22
UNT+17+ME000001'	Total number of segments in the message equals 17

Note:

The EDI interchange will include the UNB..UNZ segments and, if applicable, the UNG..UNE segments. (See part 1 section 5.7).